



CABLEMASTER™

CRM-16 & CRM-32 Cord Reels

CRM Cablemaster units, take all the work out of managing your boats shore power cable — available in both 16amp and 32amp versions, these self contained “ready to fit” systems, are supplied with 15m of high visibility yellow shore power cable and are fitted with a standard European pin and sleeve type dockside connector.

The CRM Cablemaster’s drive system features an innovative clutch mechanism that allows the storage reel to “free wheel” making it easy and quick to use — simply pull out whatever length of shore power cable is required, and when its time to retract the cable, press and hold the control switch (supplied) to engage the powerful DC motor (12v or 24v) that will effortlessly retract the cable and re-store it on the reel.

Give yourself a break — stop struggling with tangled, twisted or dirty shore power cables — fit a Glendinning CRM Cablemaster unit, and relax!

- **EASY TO USE** — to extend the cable, simply manually pull out the amount of cable you need—then to retract it, press & hold the control switch and the cable will be retracted and stored on the reel.

- **“ZERO EFFORT” PULL-OUT FORCE** — Our unique drive motor mechanism (patent pending) remains completely disengaged while the cable is being extended.

- **COMPACT STORAGE** — Self contained unit, stores 15m of cable, and can be mounted wherever there is “free space”.

- **EASY TO INSTALL** — Detachable mounting base makes it quick and easy to mount the unit in any chosen position with or without hawse pipe.

- **TESTED & APPROVED** — UL, CSA, ABYC, CE, ISO8846 (Ignition protected)

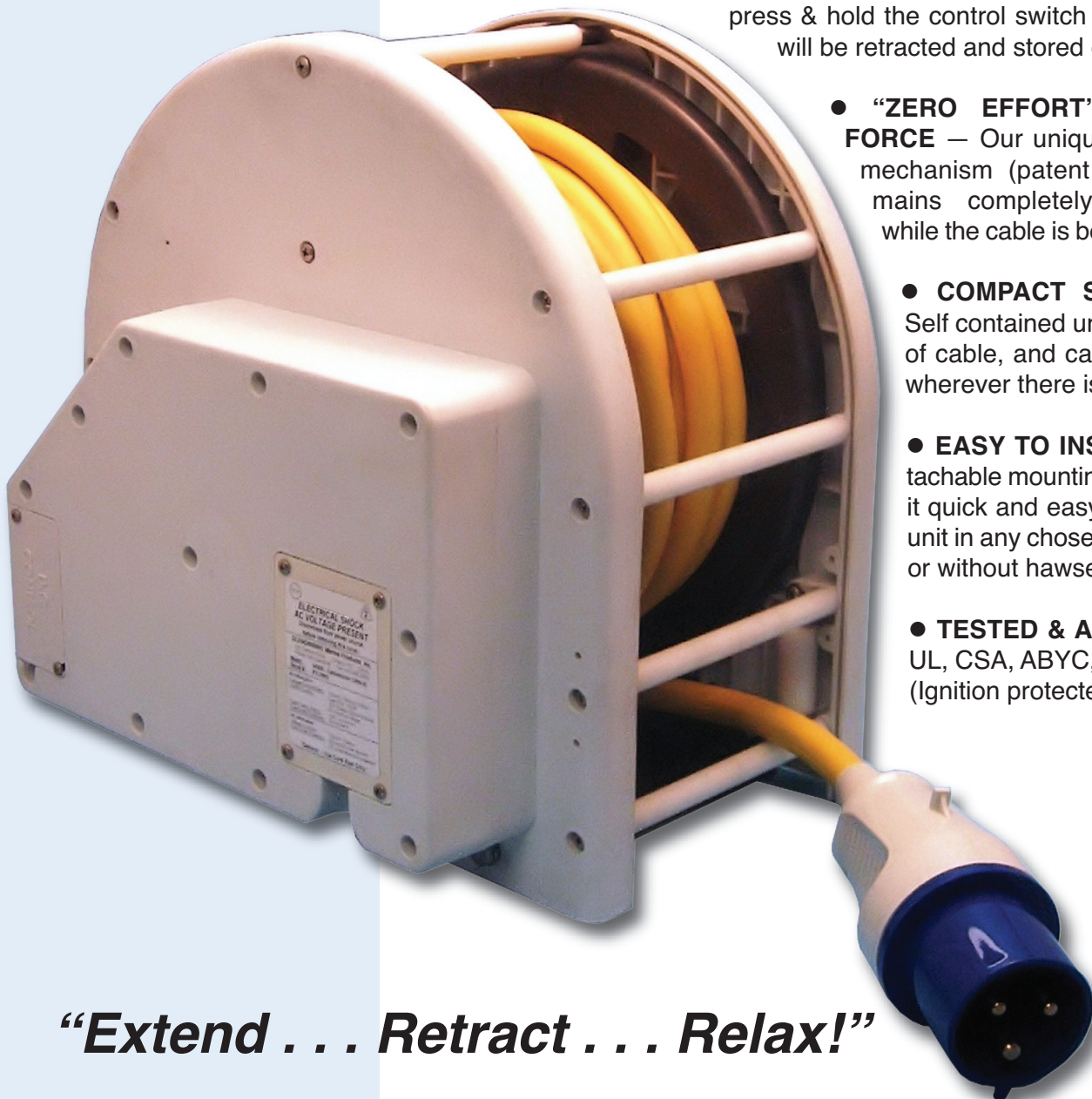

“Extend . . . Retract . . . Relax!”

CABLEMASTER™ — CRM-16 & CRM-32 SPECIFICATIONS

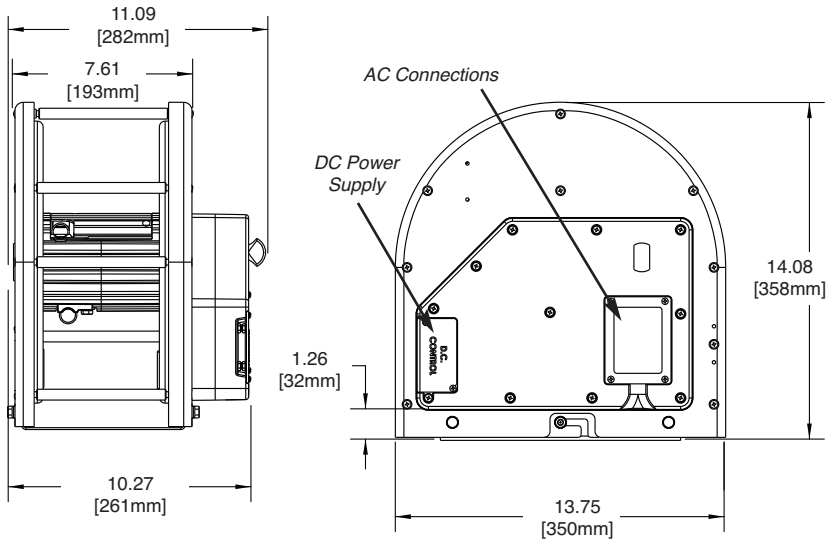

- VOLTAGE:**12 or 24 VDC
- OPERATING CURRENT:** . .3-5 amps nominal
(15 amp peak)
- CABLE:**Supplied with 15m
(16amp or 32amp) 3 core
"high visibility yellow"
- DOCKSIDE CONNECTOR:**Pre-wired
blue pin and sleeve type
- SWITCH:**Supplied with switch
and 1.8m switch cable
- WEIGHT:**16amp — 10kg [22 lbs.]
32amp — 14.5kg [32 lbs.]
- CERTIFICATIONS:** . . .UL,CSA,ABYC,CE,
ISO8846 (Ignition protected)

Part No.	Description
CRM-16-12	12v 16amp Cablemaster cord reel
CRM-16-24	24v 16amp Cablemaster cord reel
CRM-32-12	12v 32amp Cablemaster cord reel
CRM-32-24	24v 32amp Cablemaster cord reel
Options	
04049	Stainless Steel Hawse Pipe

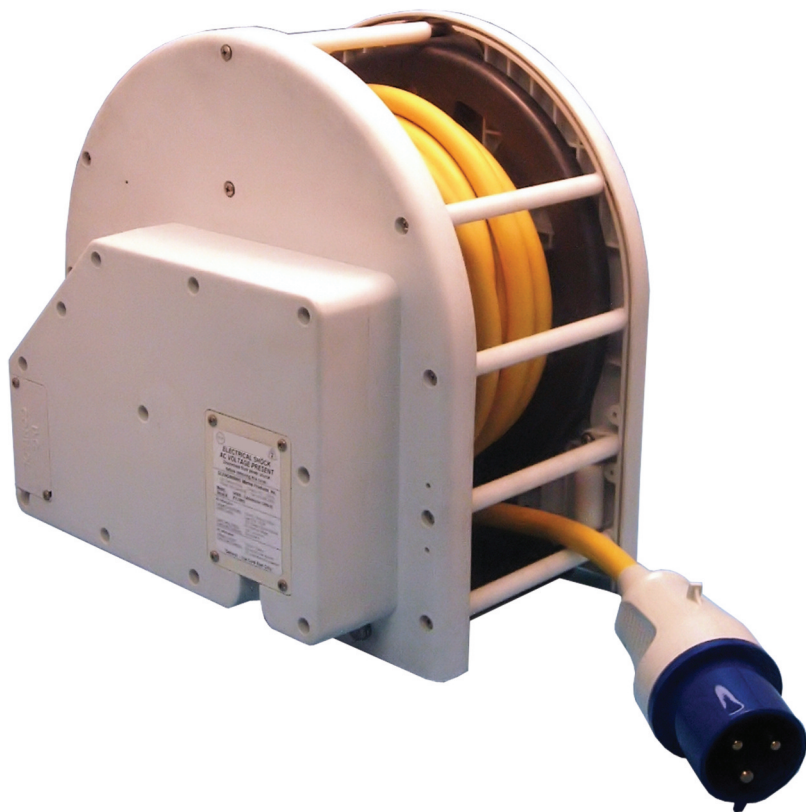

*Optional
Stainless Steel
Hawse Pipe
part number 04049*



For more information, contact our sales engineer or your local dealer today!

740 Century Circle Phone: (843) 399-6146
Conway, SC 29526 Fax: (843) 399-5005



www.glendinningprods.com
SML-CRM30-EURO_v1.0