



# HOSEMASTER™

## Powered Hose Reel Systems

**Glendinning Hosemaster systems** put an end to fighting with tangled, twisted and often dirty water hoses.

With Glendinning Hosemaster installed, washing down decks has never been easier. Both 12 or 24v versions are available supplied with various hose diameters and lengths to suit your application.

Extremely robust marine construction using anodized aluminum, stainless steel and plastic polymer components means you can be sure of their suitability for life in the harshest of environments.

All units feature Glendinnings innovative clutch mechanism, allowing you to effortlessly pull off the amount of hose required, then to retract it, push and hold the control switch and the hose will be retracted and stored on the reel ready for the next time it's required!

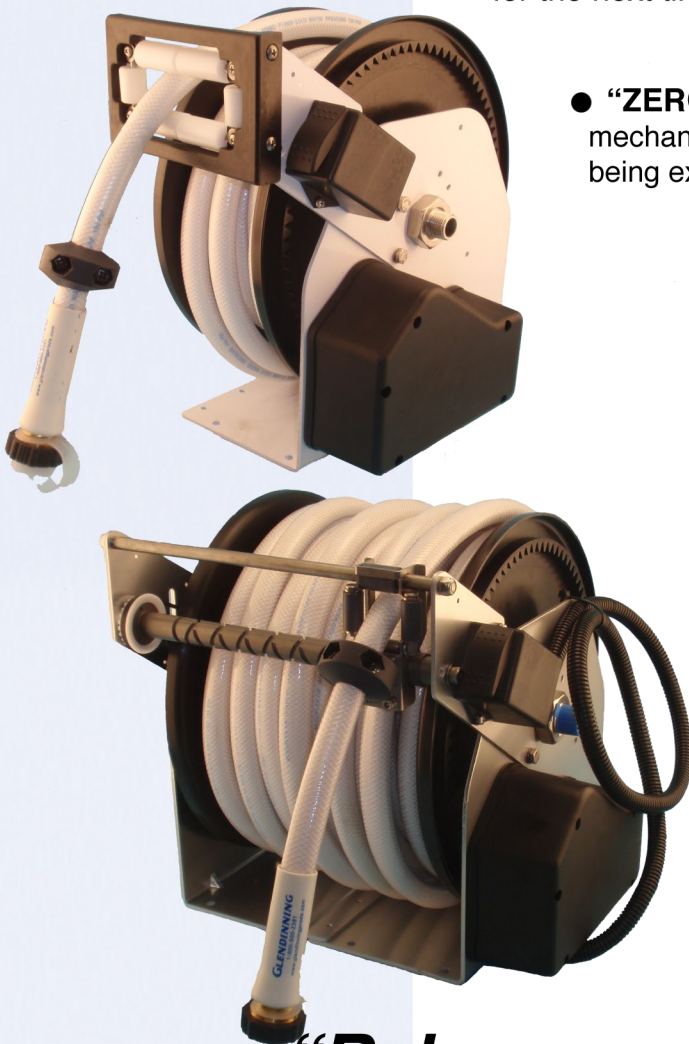

- **“ZERO LOAD” PULL OUT FORCE** - Unique drive motor mechanism remains completely disengaged while the hose is being extended.
- **EFFICIENT STORAGE** - No more trying to coil and uncoil uncooperative hoses, hose is stored neatly on its reel.
- **EASY INSTSLATION**- Supplied ready to install in any free space onboard (floor or ceiling mount).
- **LEVELWIND FEATURE** - Hosemaster LW models feature Glendinnings “levelwind” device that insure the hose is loaded onto the reel neatly allowing upto 100ft (30m) of 1/2” (12mm) hose to be stored in a very compact area.

***“Relax... we’re on board!”***

## Model M

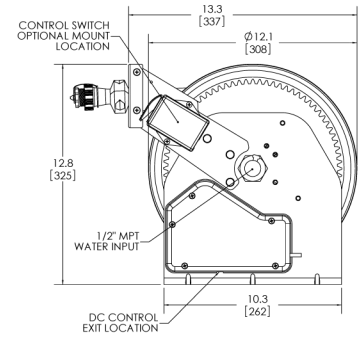
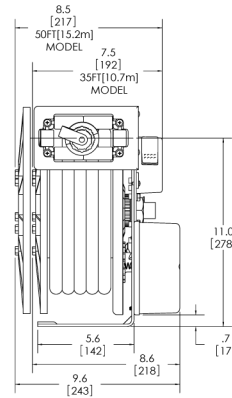
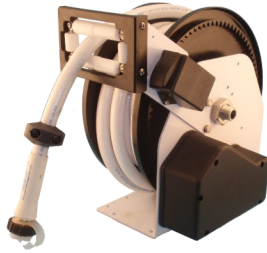

Part no	Description	Voltage (DC)	Hose ID	Hose Length	Current	Weight	
Hosemaster - M	05510-12-35	Hosemaster-1/2" 12V 35'	12v	1/2" (12mm)	35ft (10.7m)	3 amps	16lbs (7.3kg)
	05510-24-35	Hosemaster-1/2" 24V 35'	24v	1/2" (12mm)	35ft (10.7m)	2 amps	16lbs (7.3kg)
	05510-12-50	Hosemaster-1/2" 12V 50'	12v	1/2" (12mm)	50ft (15.2m)	3 amps	17lbs (7.7kg)
	05510-24-50	Hosemaster-1/2" 24V 50'	24v	1/2" (12mm)	50ft (15.2m)	2 amps	17lbs (7.7kg)

## Model LW

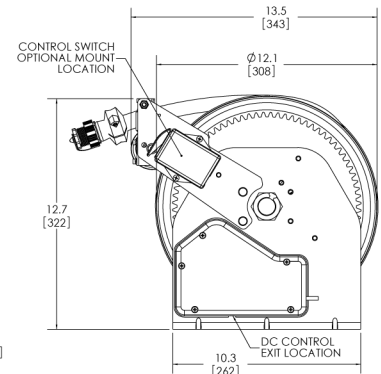
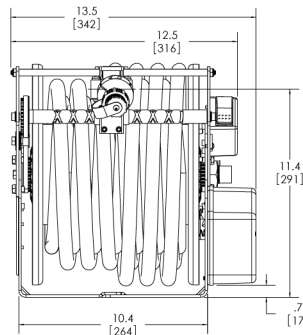
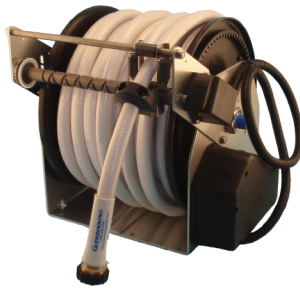

Part no	Description	Voltage (DC)	Hose ID	Hose Length	Current	Weight	
Hosemaster - L/W	05520-12-75	Hosemaster - 5/8" 12V 75' LW	12v	5/8" (15.9mm)	75ft (22.9m)	3-4 amps	27 lbs. (12.2kg)
	05520-24-75	Hosemaster - 5/8" 24V 75' LW	24v	5/8" (15.9mm)	75ft (22.9m)	2-3 amps	27 lbs. (12.2kg)
	05520-12-100	Hosemaster - 1/2" 12V 100' LW	12v	1/2" (12mm)	100ft (30.5m)	3-4 amps	27 lbs. (12.2kg)
	05520-24-100	Hosemaster - 1/2" 24V 100' LW	24v	1/2" (12mm)	100ft (30.5m)	2-3 amps	27 lbs. (12.2kg)

## Additional Specifications

**HOSE TYPE**  
**MATERIAL**  
**WATER CONNECTION INLET**  
**APPROVALS**

White, non marking, drinking water safe hose  
 Anodized Aluminum, stainless steel and plastic polymers  
 1/2" NPT  
 CE, ISO8846, NSF61, ABYC



**MADE IN THE USA**



740 Century Circle  
 Conway, SC 29526

Phone: (843) 399-6146  
 Fax: (843) 399-5005

[www.glendinningprods.com](http://www.glendinningprods.com)

SML-CRM30-EURO\_v1.0